



# Manual for installation and operation of the modular chimney system DD-1

**Be sure to read the manual  
prior to installing and operating the modular chimney system**

2023  
Vilnius

# Chimney kits for saunas

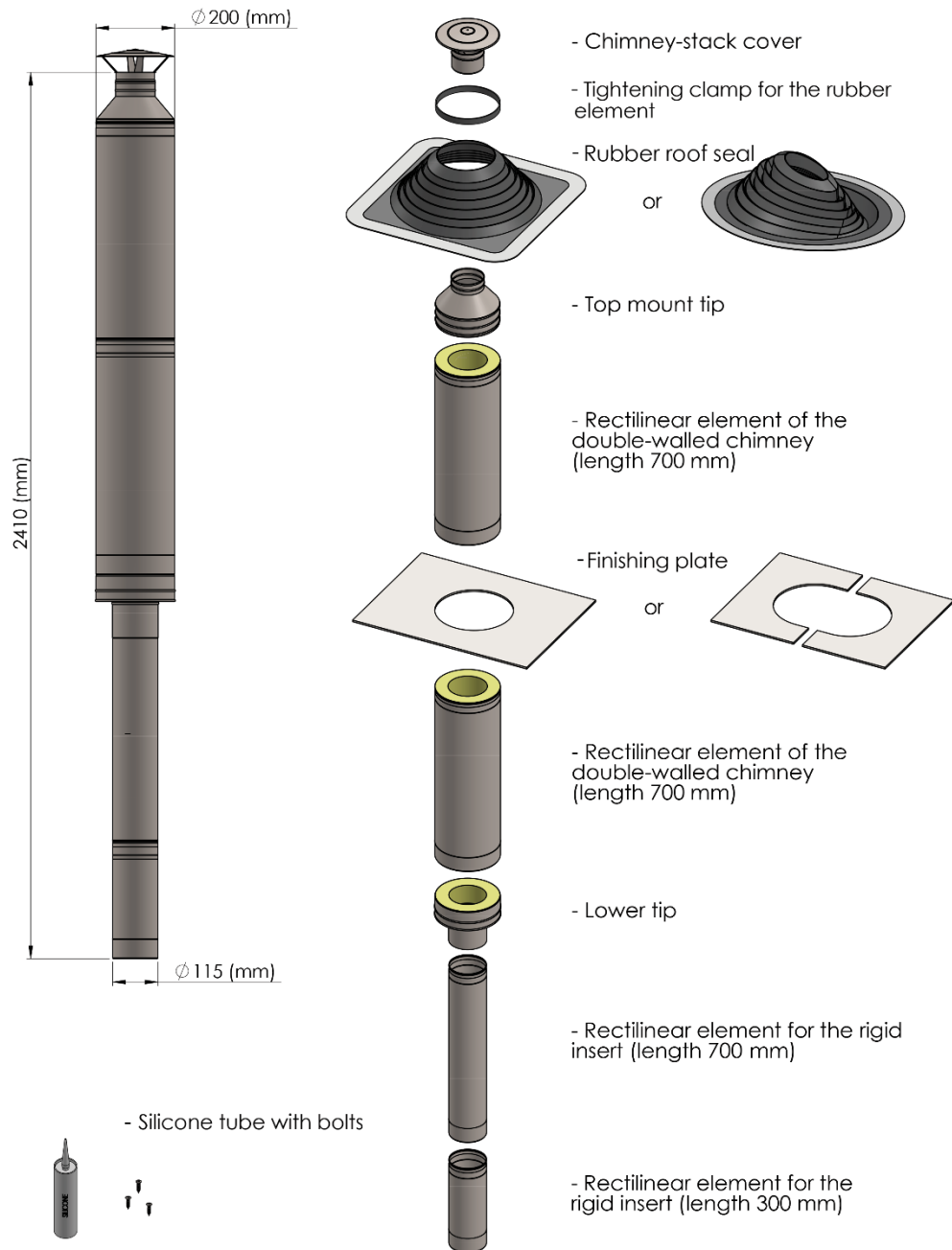

## Modular chimney system DD-1. General information

The round double-walled chimney system is designed to remove combustion products from heating units by natural chimney draft. It is suitable for gas, liquid and solid fuel boilers; the maximal temperature of combustion products is 600 ° C. The certified materials that are not harmful to human health are used for the production of chimneys. The nominal size of the inner smokestack is 115 mm, the pipe is made of stainless steel (grade 1.4404, thickness - 0.6 mm).



Fig.1.Example of identification of the elements of the double-walled chimney system

Material class	Material number	Mark
50	1,4404*	X5CrNiMo 17-12-2
Mineral wool		Paroc Wired Mat 80
20	1.4301	X5CrNi 18-10
* Equivalent 1,4571 (X6CrNiMoTi 17-12-2) of material No.1.4404		

Fig.2. Material specification

**It is necessary to strictly adhere to the parameters stated in the product specification when designing, installing and operating chimneys, inserts and fittings.**

### Installation of the elements of the modular chimney system DD-1

Assembly of the double-walled chimneys is carried out as follows: the inner chimney pipes are threaded one pipe on the other "according to the condensate", whereas the outer pipe of the upper segment must cover up the outer pipe of the lower segment (see Fig.3), thus, blocking the penetration of rain inside the chimney.

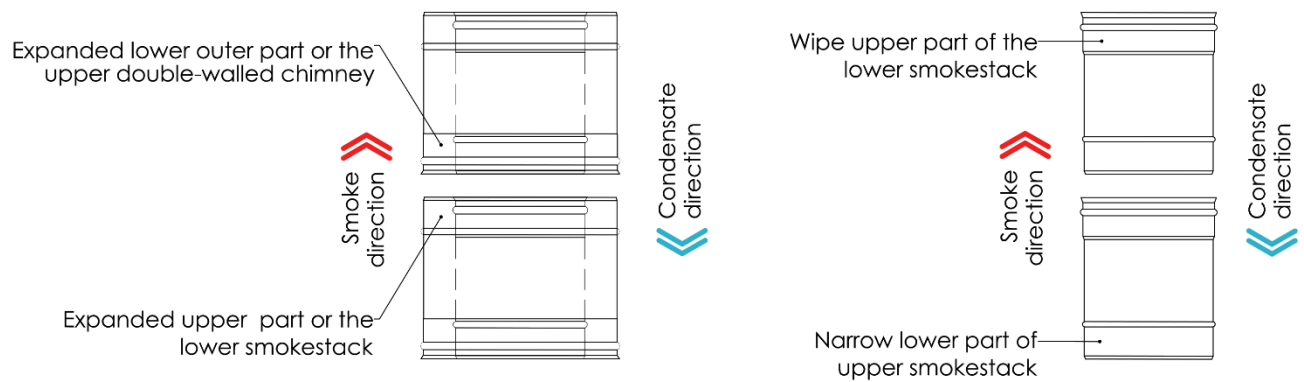

Fig.3.Assembling of the double-walled chimney

The inner pipes must be tightly connected by using the silicon "Fire Sealant", 1200°C, the manufacturer "Den Braven", the address: Denariusstraat 11, 4903RC, Oosterhout, the Netherlands. When installing the chimney, only the outer pipes are fastened with the rivets ISO 159834x8A2/A2 made of stainless steel. The quantity of rivets depends on the diameter of the outer wall. The quantity of rivets is stated in Table No.1.

Table 1

Diameter of the outer pipe, mm	Quantity of rivets, pcs.
200	3
>200	4

**When installing the chimney, you must keep safe distances:**

- the distance of at least 130 mm must be kept between the outside of the double-walled chimney and combustible materials;
- the distance of at least 500 mm must be kept between the non-insulated smokestack and combustible materials;
- the non-insulated part of the smokestack must be protected (for example, with the help of the grid), so as to avoid the possible accidental human contact with the surface;
- holes of the appropriate size must be made in the places of intersection of the chimney with the building structures (the ceiling, roof, wall) (the diameter of the chimney plus the double distance to the combustible materials). The spaces must be filled with the insulating noncombustible material, attributed to the class "A", with the operating temperature of 600 ° C and higher. **It is prohibited** to connect the elements of the chimney in the places of their intersection with the building structures (see Fig. 4). The distance from the outside of the chimney to the combustible materials must be not less than 130 mm;
- the maximal height of the chimney segment, which is mounted above the last support, must be 2 m.

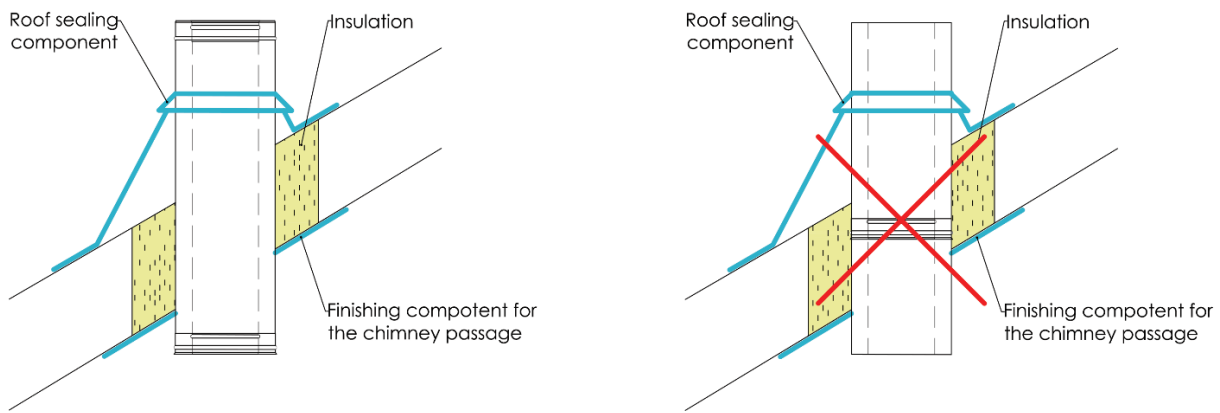

Fig.4. Mounting of the chimney system in the places of intersection with the building structure

### Installation of the rubber roof seal

The rubber roof seal is designed to protect the inner elements of the roof from moisture due to precipitation. When dealing with the high-relief roofing profiles, it is necessary to install a flat metal plate covering the hole formed by the chimney in the place of intersection with the roof construction. The following actions will ensure the proper installation of the rubber sealing element:

- Put the rubber sealing element on the top edges of the chimney; pull the rubber element downwards, if necessary, using a soap solution as a lubricant because the diameter of the rubber sealing element must be smaller than the diameter of the chimney-stack by 20%.
- Press the edges of the rubber roof seal against the roof surface. Affix the lower part of the rubber roof seal to the roof surface with the help of the frost and water resistant sealant. Remove the excess sealant;
- Fasten the edges of the rubber element to the roof with the help of screws or metal plate by keeping the distance of 35 mm;
- Install the clamp on the upper part of the rubber seal by using the tool, which is contained in the kit.

### Installation of the chimney-stack cover

Insert the cover deeply into the chimney-stack upper tip. Do not tighten it tightly because it will be necessary to remove it when cleaning the chimney-stack.

### Installation of the ceiling plate

The ceiling plate is used for closing the chimney hole on the horizontal or sloping (up to 12 degrees) surfaces. It consists of two elements.

- Place the elements of the plate around the chimney-stack by avoiding contacting the chimney surface, so as to close the hole;
- Affix the edges of the plate to the ceiling with the help of screws.

### Chimney cleaning

Use special tools made of polymer materials or stainless steel for cleaning the chimney